

EARLY 1973







**NEVEL
KNIEVEL**

SCRAMBLE VAN



**EVEL
KNIEVEL**

SCRAMBLE VAN

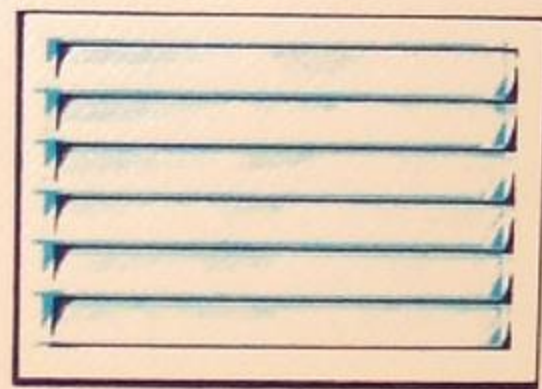





5052-01

© 1973 IDEAL TOY CORP.

HOLLIS N.Y. 11423











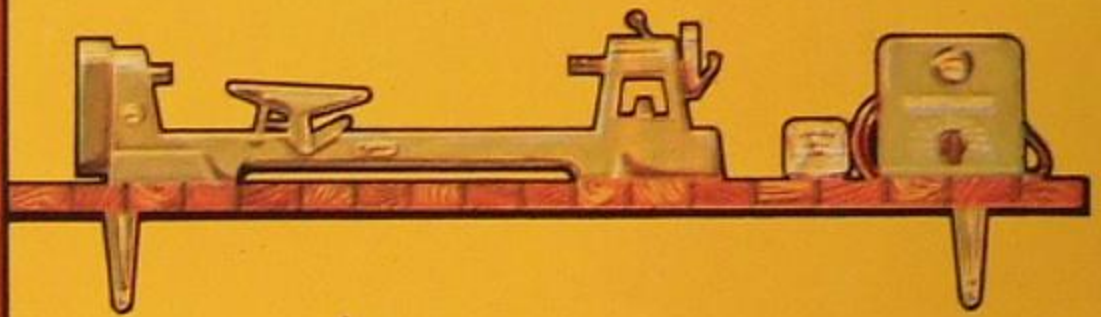
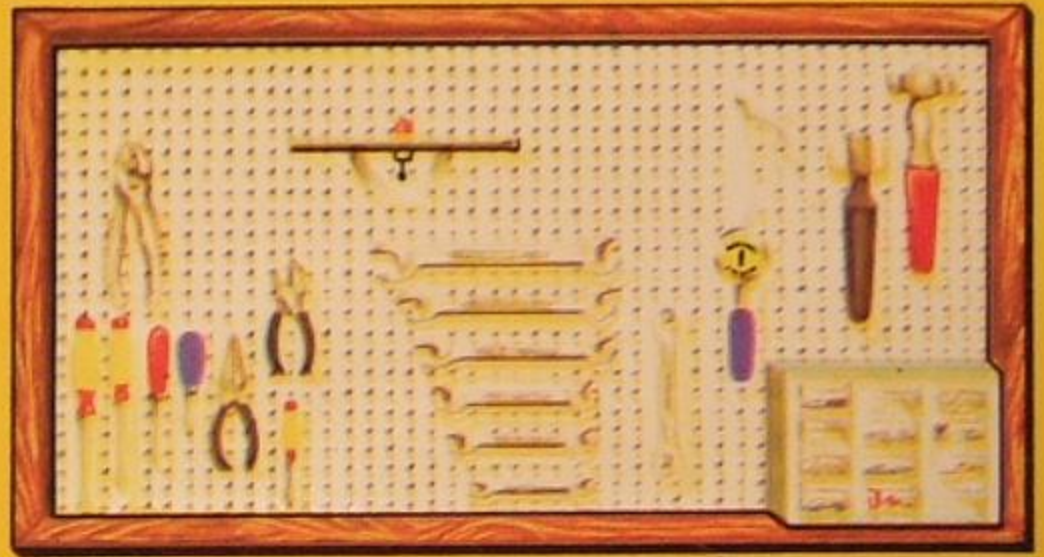



**LEVEL
KNIEVEL**

SCRAMBLE VAN



**LEVEL
KNIEVEL**

SCRAMBLE VAN



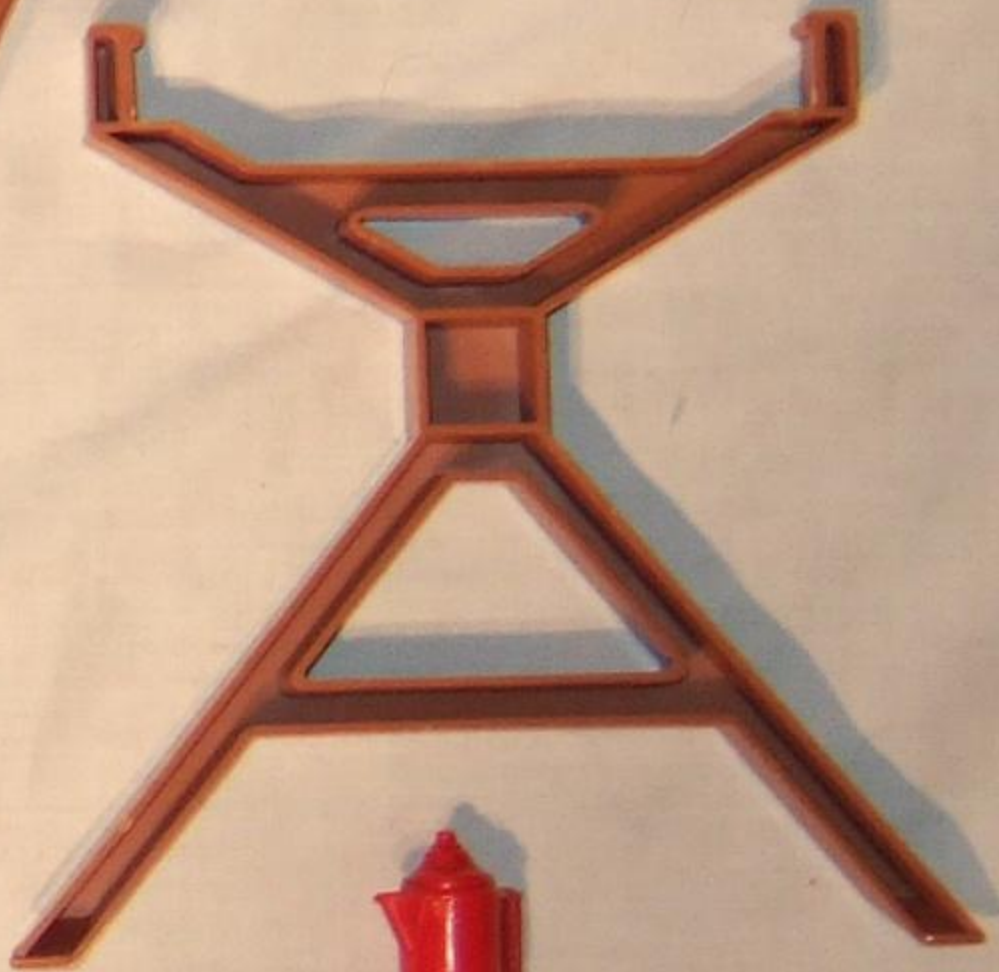
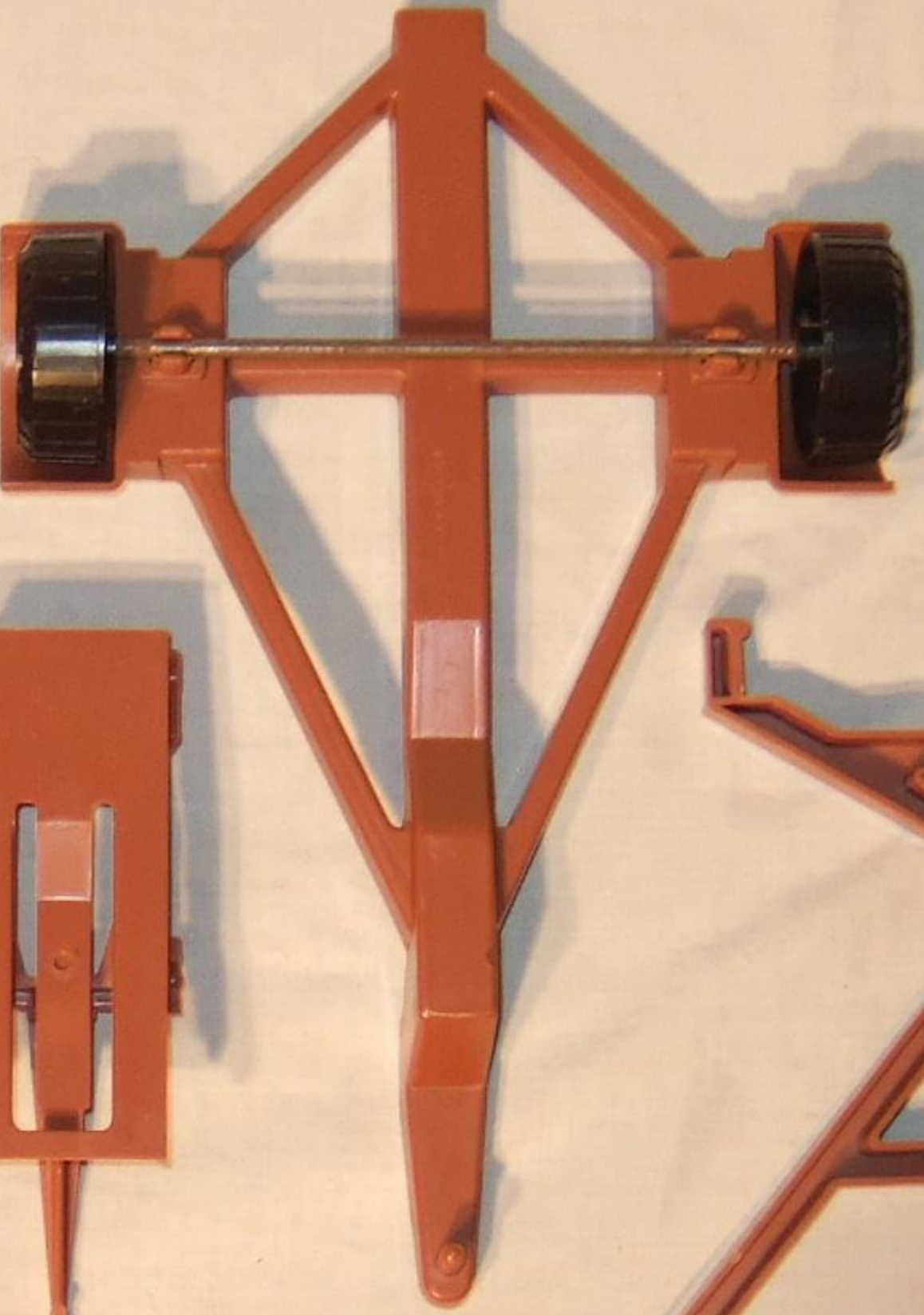

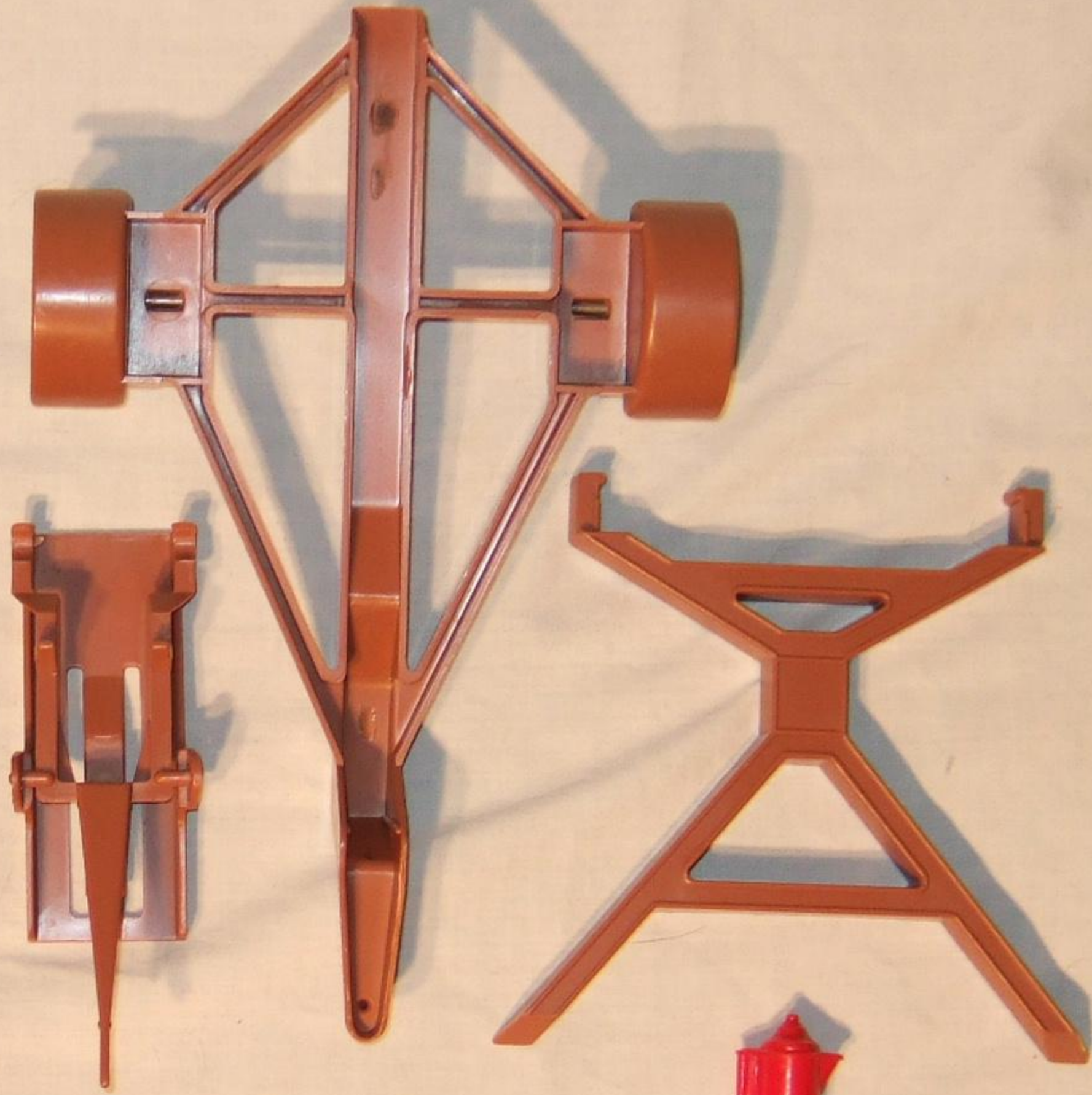
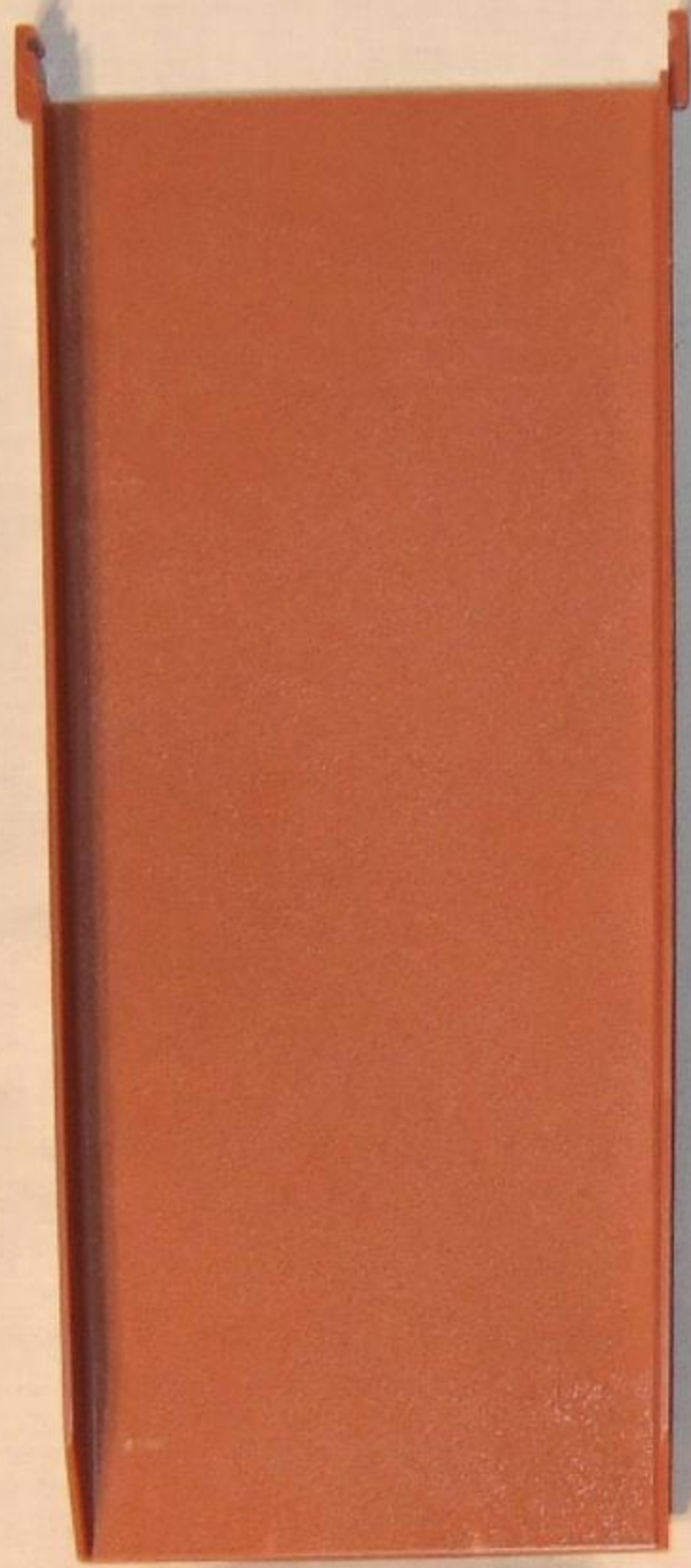



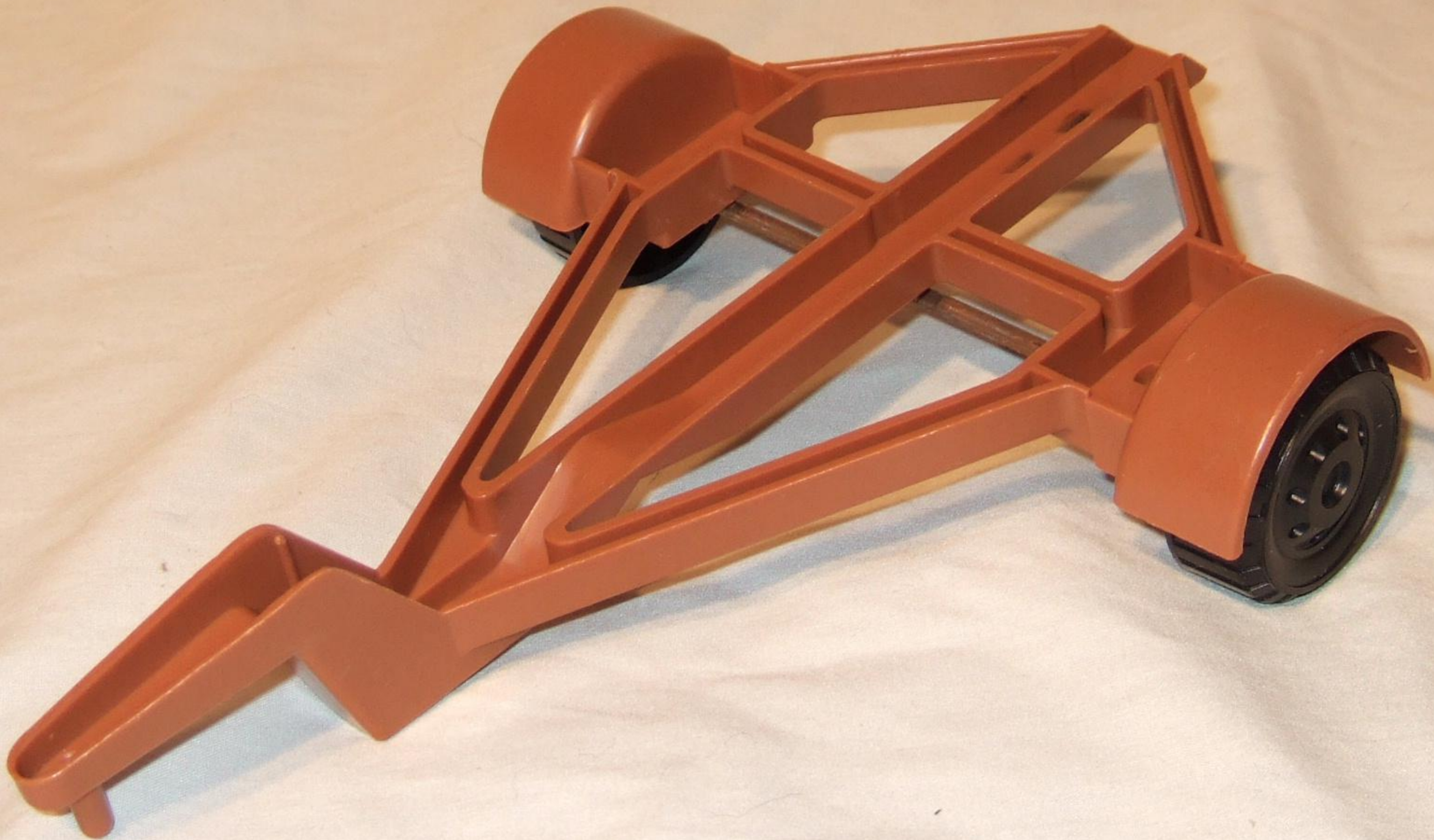



1974





5
1
1
1
5

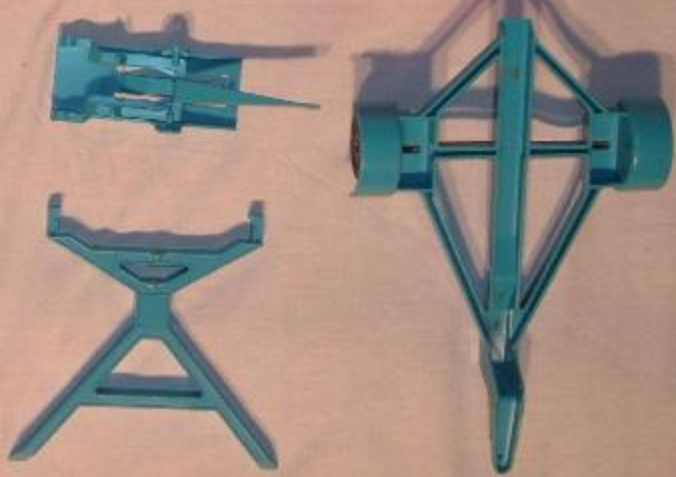

1975



GREAT THRILL JUMP

KING OF THE STUNTMEN
EVEL KNIEVEL

KING OF THE STUNTMEN
EVEL KNIEVEL

SCRAMBLE VAN



COMPLETE WITH JUMP RAMP, CYCLE JACK, CYCLE TRAILER,
WORKBENCH & TOOLS / **EVEL KNIEVEL FIGURE AND CYCLE NOT INCLUDED**

IDEAL

No. 3408-2

TOY CORP., HOLLIS, N.Y. 11423



KNIEVEL
KING OF THE SKYWAY
THE GREAT ESCAPE ARTIST

SCRAMBLE VAN



IDEAL
FOR CHILDREN 5 AND UP

**COMPLETE WITH JUMP RAMP,
CYCLE JACK, TRAILER,
MOTORBENCH & TOOLS.
EVEL KNIEVEL FIGURE AND
CYCLE NOT INCLUDED.**



IDEAL

**NOT INCLUDED
AND CYCLE
FIGURE
EVEL KNIEVEL
MOTORBENCH
& TOOLS**

SCRAMBLE VAN

KNIEVEL
KING OF THE SKYWAY
THE GREAT ESCAPE ARTIST

No. 3408-2



SCRAMBLE VAN

KNIEVEL
KING OF THE SKYWAY
THE GREAT ESCAPE ARTIST

SCRAMBLE VAN
KNIEVEL

SCRAMBLE VAN
KNIEVEL

IDEAL



KING OF THE STUNTMEN **EVEL KNIEVEL™**

SCRAMBLE VAN



COMPLETE WITH JUMP RAMP,
CYCLE JACK, CYCLE TRAILER,
WORKBENCH & TOOLS
EVEL KNIEVEL FIGURE AND
CYCLE NOT INCLUDED



FOR CHILDREN 5 AND UP

COMPLETE WITH JUMP RAMP, CYCLE JACK,
CYCLE TRAILER, WORKBENCH & TOOLS -
EVEL KNEIVEL FIGURE AND CYCLE NOT INCLUDED



● Complete with detachable Bike Trailer to carry Evel Knievel's Stuntcycle on tour!



● Set up the Jump Ramp and Evel Knievel can soar completely over the Van on his Stuntcycle!

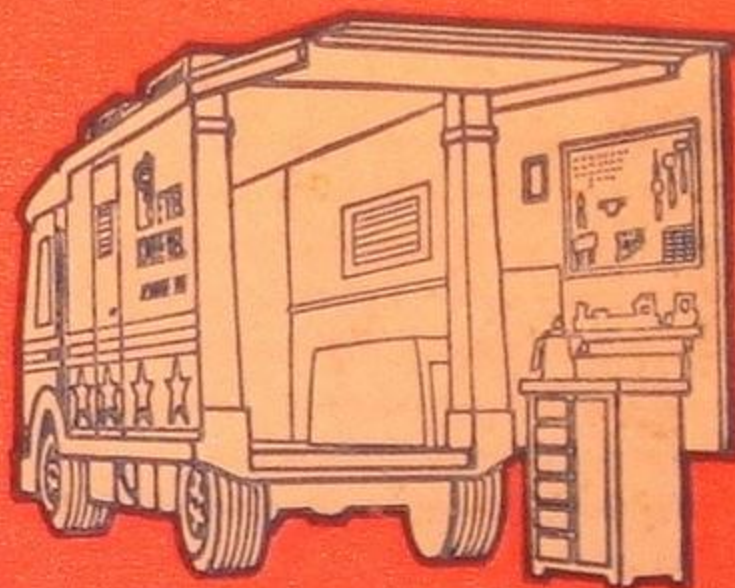

● Join back and side panels to form an open-air workshop where Evel Knievel can tune up his bike!

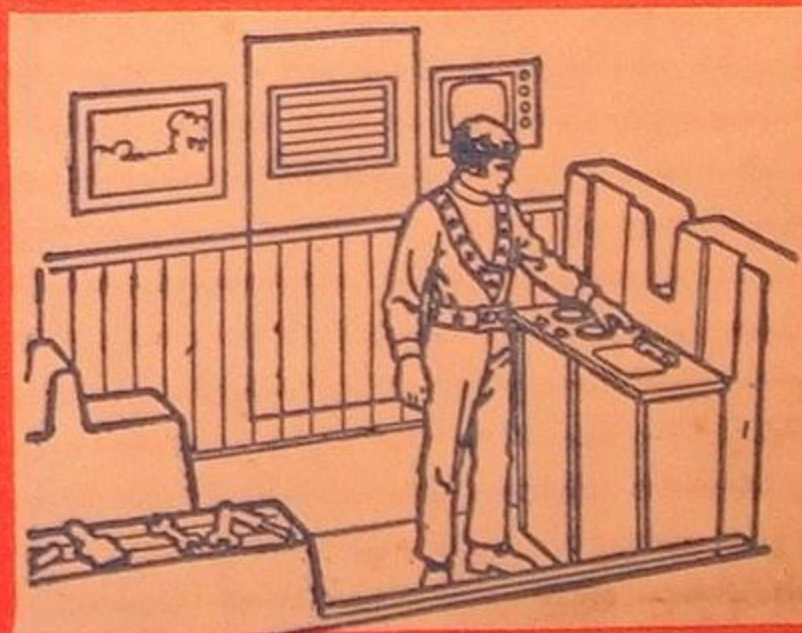

● Remove side panel and play with Evel Knievel in his combination office/living quarters!

KING OF THE STUNTMEN **EVEL Knievel™**

SCRAMBLE VAN



COMPLETE WITH JUMP RAMP,
CYCLE JACK, CYCLE TRAILER,
WORKBENCH & TOOLS
EVEL KnieVEL FIGURE AND
CYCLE NOT INCLUDED



FOR CHILDREN 5 AND UP

KING
OF THE
STUNTMEN **EVEL**
KNIEVEL™

SCRAMBLE
VAN

COMPLETE WITH
JUMP RAMP,
CYCLE JACK,
CYCLE TRAILER,
WORKBENCH
& TOOLS —

EVEL KNIEVEL
FIGURE
AND CYCLE
NOT INCLUDED

IDEAL



© 1973 IDEAL TOY CORP., HOLLIS, N.Y. 11423

No. 3408-2

KING OF THE STUNTMEN
EVEL KNEIEVEL™

★

SCRAMBLE VAN ★

★

COMPLETE WITH
JUMP RAMP,
CYCLE JACK,
CYCLE TRAILER,
WORKBENCH
& TOOLS —

**EVEL KNEIEVEL
FIGURE
AND CYCLE
NOT INCLUDED**



Van Windshield

Lift WINDSHIELD up, then slide it under CAB ROOF to place Evel Knievel figure (not included) in the front seat.

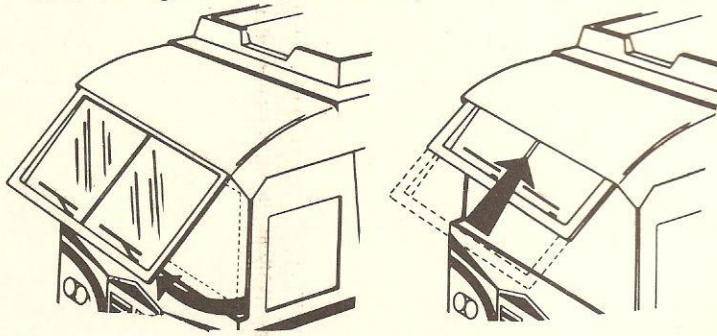

Side Panels

Both side panels of the Van slide back or completely out for easy play access to both sides of Van. In addition, the left panel has a door that swings in and out.

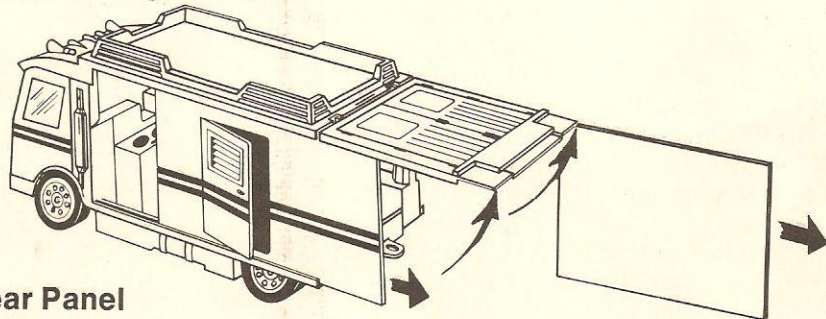

Rear Panel

To form an outdoor workshop or lounge area, raise rear door of Van. Slide right-hand side panel back beneath edge of raised rear panel as a back wall. Place SHORT SUPPORT under end corner of right-hand panel, and end of LONG SUPPORT SHAFT into square hole under left rear corner of raised back panel.

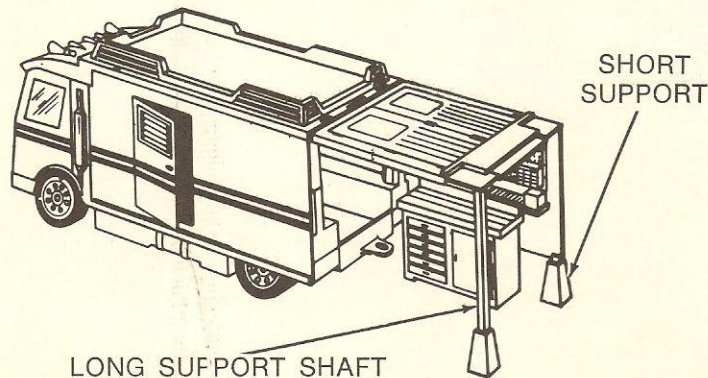

KING OF THE STUNTMEN EVEL KNIEVEL VANTM SCRAMBLE VANTM



INSTRUCTIONS



Your SCRAMBLE VAN is based on the fabulous rolling workshop/office/lounge in which Evel Knievel—the world's greatest motorcycle stuntman—tours the country giving his fantastic daredevil exhibitions. The SCRAMBLE VAN features a slide-up windshield, flip-up rear door, and slide-out side panels to give you lots of ways to play! All furniture and small accessories can be stored inside the Van, while the Jump Ramp and its support fit neatly on top and the Bike Trailer hitches on behind.

ASSEMBLY AND OPERATION OF VAN FEATURES AND ACCESSORIES

Tool Box

Insert TABS on LID into SLOTS in BASE and close LID. Box can now be opened and closed without removing LID.

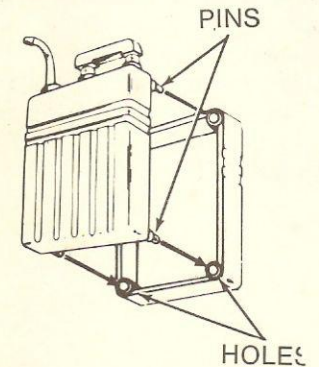
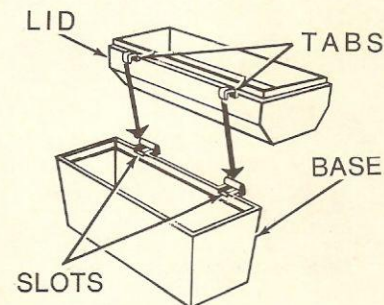

Gas Can

Snap PINS on one of GAS CAN into HOLES in other half.

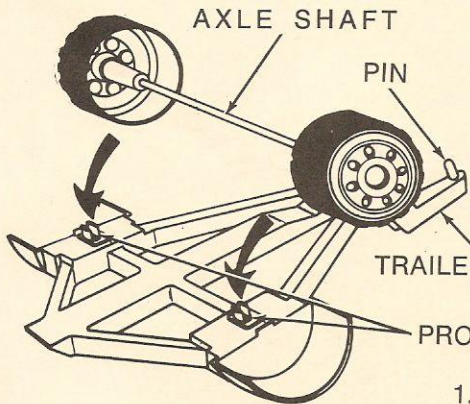

Bike Trailer

Snap AXLE SHAFT into PRONGS underneath TRAILER as shown. Trailer can be attached to Van by inserting PIN on TRAILER TONGUE into HOLE in TAB at rear of Van.

Jump Ramp

1. Snap upper and lower sections together as shown.
2. Snap RAMP SUPPORT onto RAMP as shown.

To perform a jump over the Van, place TAB beneath top end of RAMP into SLOT at rear of Van roof. Launch Stuntcycle (not included) directly toward RAMP from a distance of approximately 18 inches from bottom end of RAMP. For a regular jump, seat Evel Knievel on the Stuntcycle with his hands gripping the handlebars. With a lot of practice, you may even be able to make him do a flip while jumping—to attempt this, lean the figure forward on the Stuntcycle with hands OFF the handlebars.

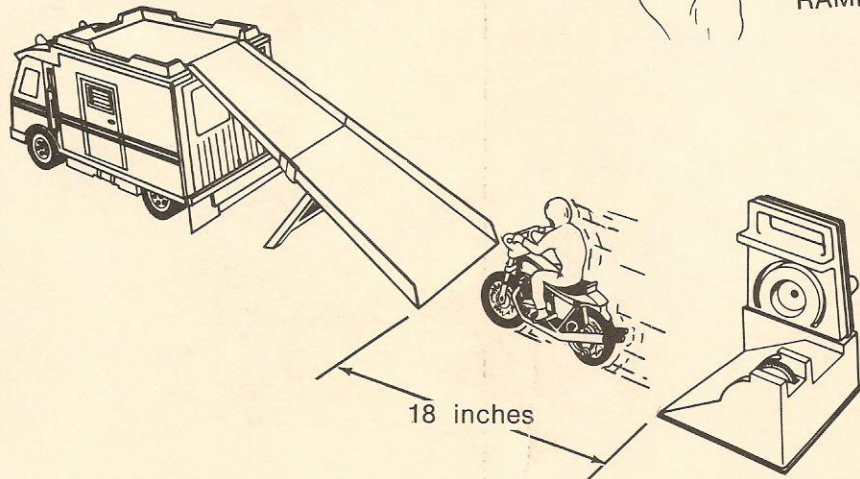
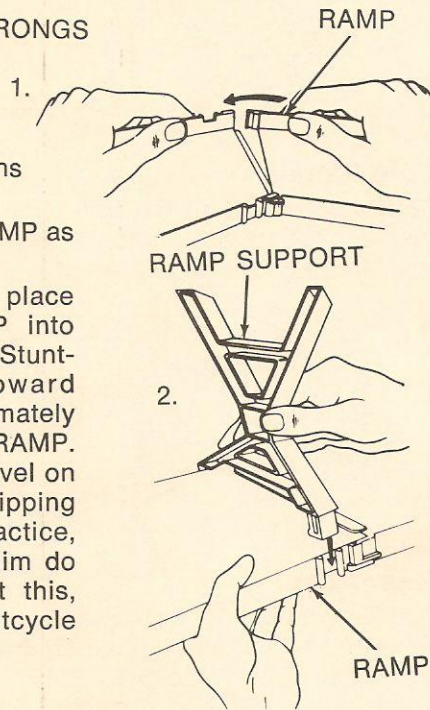

GAS CAN (and FIRE EXTINGUISHER) can be mounted on BIKE TRAILER.

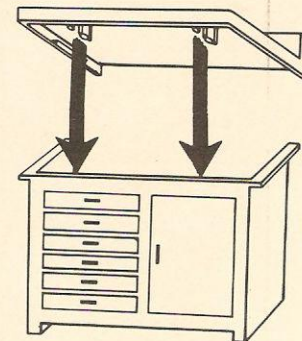
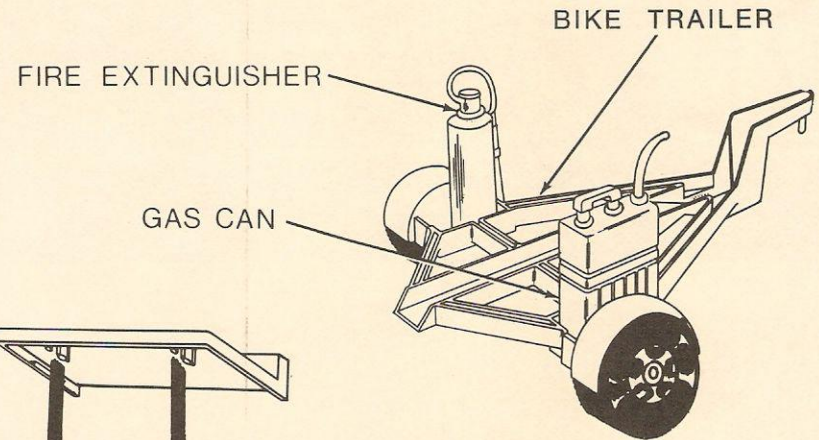

Work Bench

Snap TOP onto BOTTOM as shown.

Bike Jack

Snap side PINS on FORK into HOLES in TABS on BASE. To operate JACK, set rear or front wheels of cycle on FORK in position shown, and press LEVER down until it locks. To release JACK, pull firmly up on LEVER.

